

CM 200

Cleaning Machine

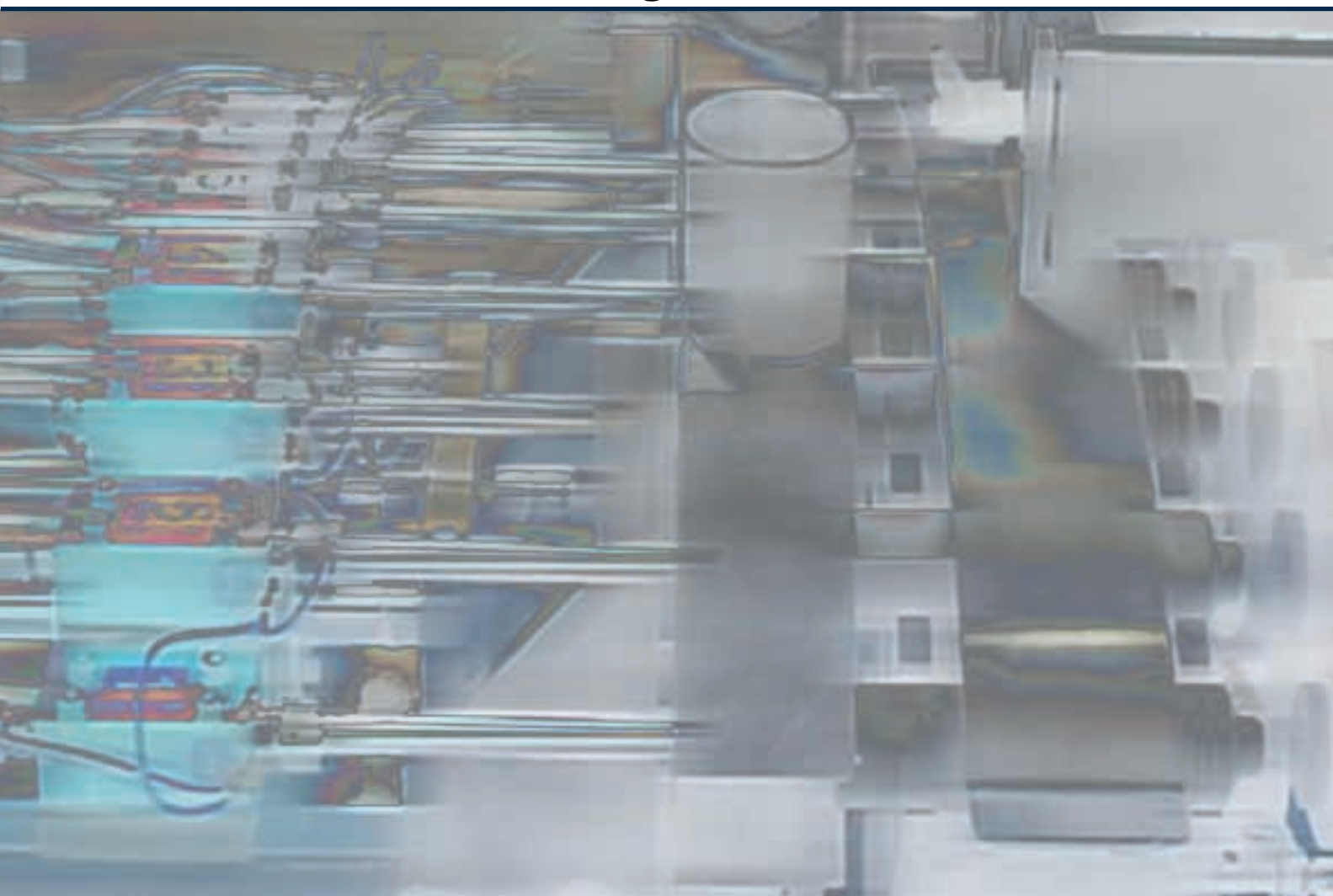

MARTINENGHI srl



Cleaning Machine

Clean your tubes to improve your quality

CM200 is a new machine equipped with a system for cleaning aluminium and plastic tubes. A transport device moves the tubes under a law of variable speed motion and stops the tubes in the working station. Nozzles blow microfiltered and ionized air inside the tubes to neutralize the static charges and to remove the foreign particles which are taken out through a centralized suction unit.

The tubes loading and unloading systems are designed to allow an easy installation of the machine in any kind of line. Format change operations are very simple.

The CM200 machine has the characteristics required to make it the trustworthy partner of manufacturers aiming at state-of-the-art quality and service.

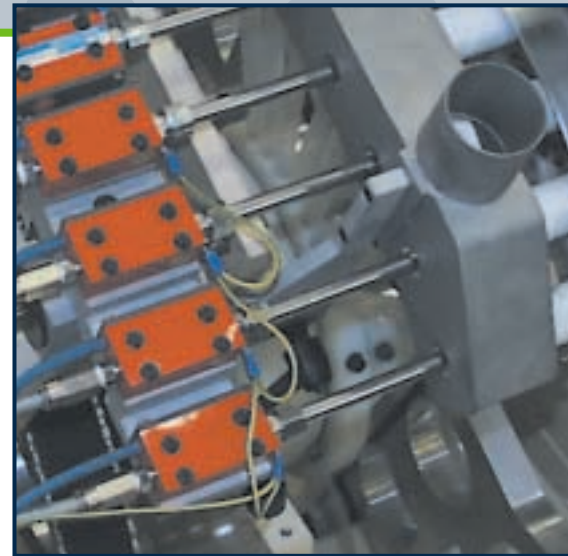
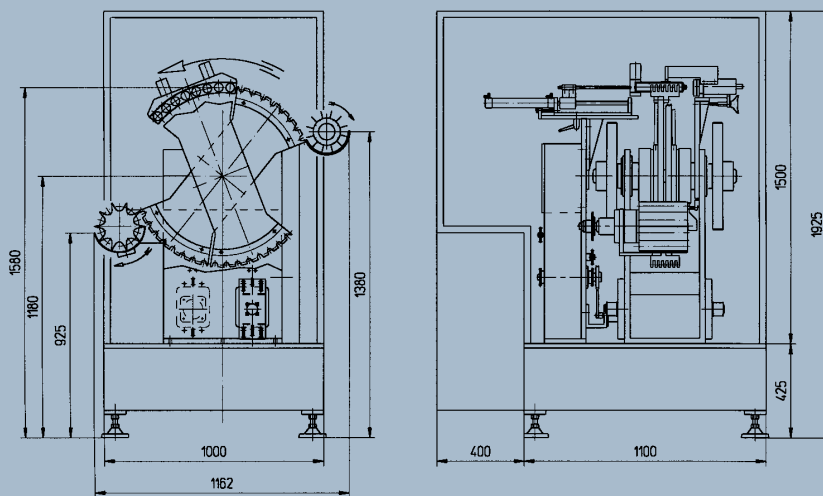

Technical features

Minimum tube diameter	mm	11
Maximum tube diameter	mm	40
Minimum tube length	mm	50
Maximum tube length	mm	210
Adjustable production rate up to	ppm	200
Number of cleaning units	n	8
Number of controlled axes	n	2
Air consumption	Nm³/h	40
Installed capacity	kW	4
Machine weight	kg	1000

Technical features and descriptions could be modified without notice



MARTINENGI s.r.l.